



TOWN

發公司
富司

FOOD SERVICE EQUIPMENT CO., INC.

800/221.5032 718/388.5650 718/388.5860 customer@townfood.com www.townfood.com

Item Number _____

Project _____

Quantity _____



SR-24-C 16" Cantonese Chamber Wok Range

Models

SR-24-C is available for use with either Natural or Propane fuel. The unit is designed for use with 18"-20" Cantonese style woks. The unit can be converted for use as a stock pot range by purchasing a grate top.

General

Complete stainless steel exterior using fully welded construction. No exterior fasteners are used.

The SR-24-C utilizes Town's heavy duty stock pot stove body coupled with a powerful burner to offer true Asian cooking in minimal space and without the need for water cooling. A Town high input (137 MBTUH) 3 ring burner is supplied with this unit. Jet style burner choices are available (refer to our burner cut sheet for selection). The unit is supplied with Town's exclusive clog resistant pilot. An aluminized heat shield between the combustion chamber and outer body ensures cool operation of the unit. Delta T rated solid brass valves with solid metal handles are standard. The outer body and legs are stainless steel. A rugged interior chassis, formed from heavy duty steel angle iron is standard. Rear gas connection, pressure regulator and a stainless steel drip tray are standard.

Standard features

- Design certified by ETL to conform to ANSI Z 83.11-2009
- Design certified by NSF International and/or ETL to conform to ANSI/NSF-4
- Heavy duty 16" steel wok chamber, black epoxy painted finish
- Interior heat shield
- Solid brass Delta T rated valves
- All stainless steel exterior construction
- Rigid, durable angle iron chassis
- High power 3 ring burner with two control valves for maximum heat control
- Clog resistant standing pilot/with control valve
- Stainless steel legs with "bullet" adjusters
- 3/4" NPT rear gas connection with regulator
- NYC OTCR and MEA approved
- MA Board of Plumbing and Licensure approved

Options

- Volcano, shield (duck) tip, 23 and 32 tip jet burners are available
- Custom leg height
- Double insulated chassis
- Casters with cross bracing
- Pilot gas safety system
- Asian smallwares, such as woks, ladles and shovels



STANDARD DIMENSIONS AND TECHNICAL DATA

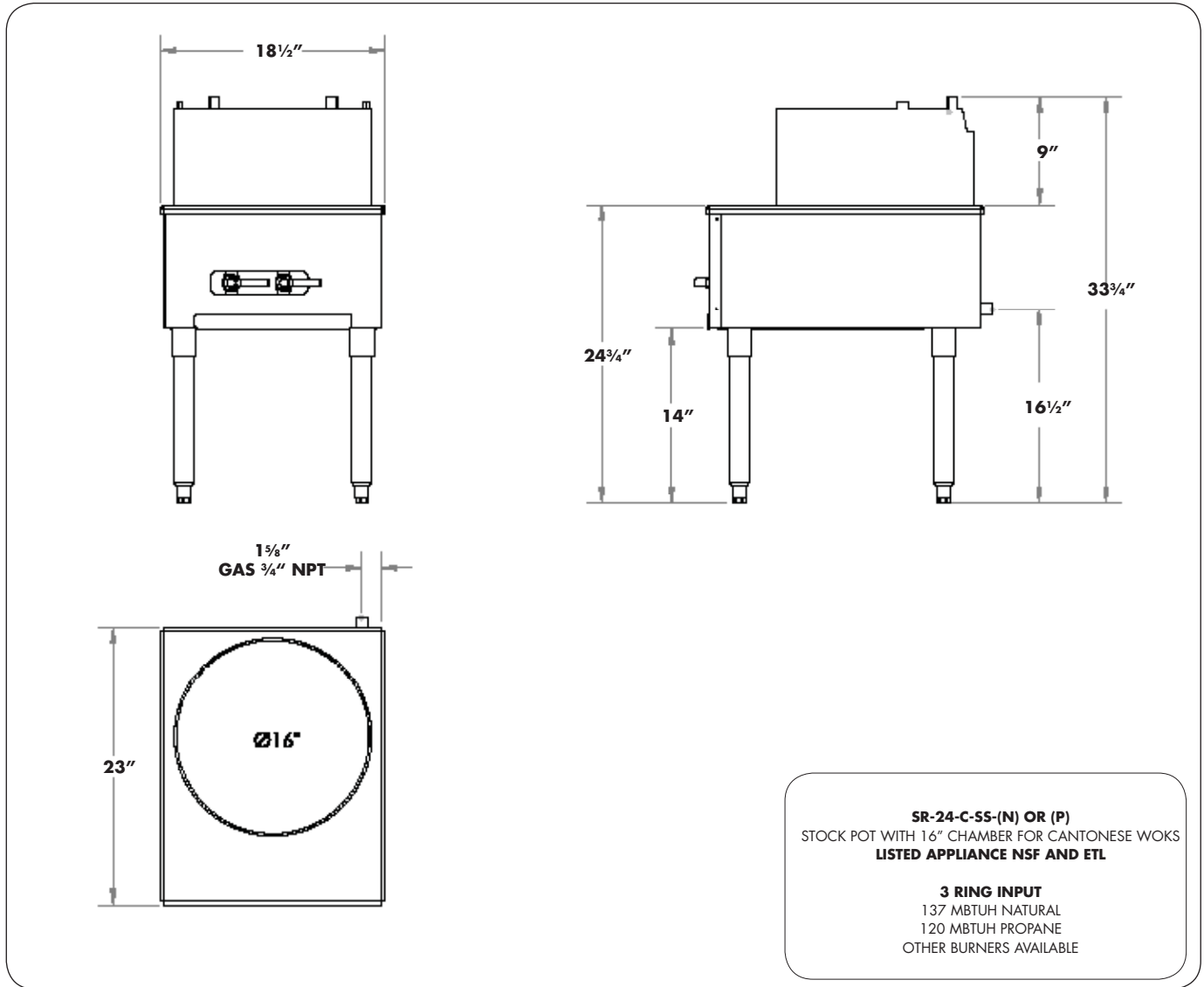

IMPORTANT

Commercial gas range(s) must be installed in accordance with state and local codes, or in the absence of local code with the NATIONAL FUEL GAS CODE- ANSI Z223.1. COMPLIANCE WITH ALL CODES IS THE RESPONSIBILITY OF THE OWNER AND THE INSTALLER.

COMMERCIAL GAS UNITS NEED ADEQUATE VENTILATION SYSTEMS. REFER TO *National Fire Protection Association Standard No. 96- "Vapor Removal from Cooking Equipment"*

CERTIFIED BY ETL TO CONFORM TO ANSI Z83.11- "GAS FOODSERVICE EQUIPMENT." Not intended for household use. For use by professionally trained personnel only.

CERTIFIED BY ETL/NSF TO NSF4/ANSI-4-COMMERCIAL COOKING, RETHERMALIZATION AND HOT FOOD EQUIPMENT- "SANITATION."

MINIMUM CLEARANCES- COMBUSTIBLE AND NON COMBUSTIBLE:

Back Wall- 6" Left and Right Sides- 6" For use on non combustible floors only.

TOWN RESERVES THE RIGHT TO CHANGE DESIGN WITHOUT NOTIFICATION.



TOWN

Town Food Service Equipment Co., Inc. logo in Chinese characters: 豐公司

FOOD SERVICE EQUIPMENT CO., INC.

800/221.5032 718/388.5650 718/388.5860 customer.service@townfood.com www.townfood.com