



TOWN

FOOD SERVICE EQUIPMENT CO., INC.



Item Number _____

Project _____

Quantity _____



800/221.5032
718/388.5650



718/388.5860



customerservice@townfood.com



townfood.com



SR-24-G-2X Double-Grate-Top Stock Pot Stove

PICTURED WITH OPTIONAL UNDERSHELF



This double stock pot stove delivers blindingly-fast performance, for braziers, stock or saute. Metal valve handles, with heat-shield protection, from the combustion chamber, stay cool. Welded all stainless steel construction, including optional undershelf and drip tray, assure sturdy and reliable use. Rear gas connection, with pressure regulator, are standard. High-powered 3-ring burners, with clog resistant pilots.

The SR-24-G-2X is a high-quality stockpot range, built for hard use. A work horse of a range, the SR-24-G-2X will meet the needs of even the most demanding chefs.

FEATURES

- 'Stay Cool' valve handles
- Solid construction
- 2 cast iron tops, with an easy-to-clean front ledge

OPTIONS

- Caster set
- Stand/undershelf
- Wok adapter for SR-24 grate top
- Insulated, double-wall construction

MODEL SIZES, WEIGHTS AND MEASUREMENTS

MODEL NO.	DEPTH	WIDTH	HEIGHT	SHIP WEIGHT	GAS CONNECTION	MBTUH
SR-24-G-2X-N/P	24 1/4"	38"	18"¹	450 lb.	1 1/4"	274

N (natural gas), P (propane)

STANDARD DIMENSIONS AND TECHNICAL DATA

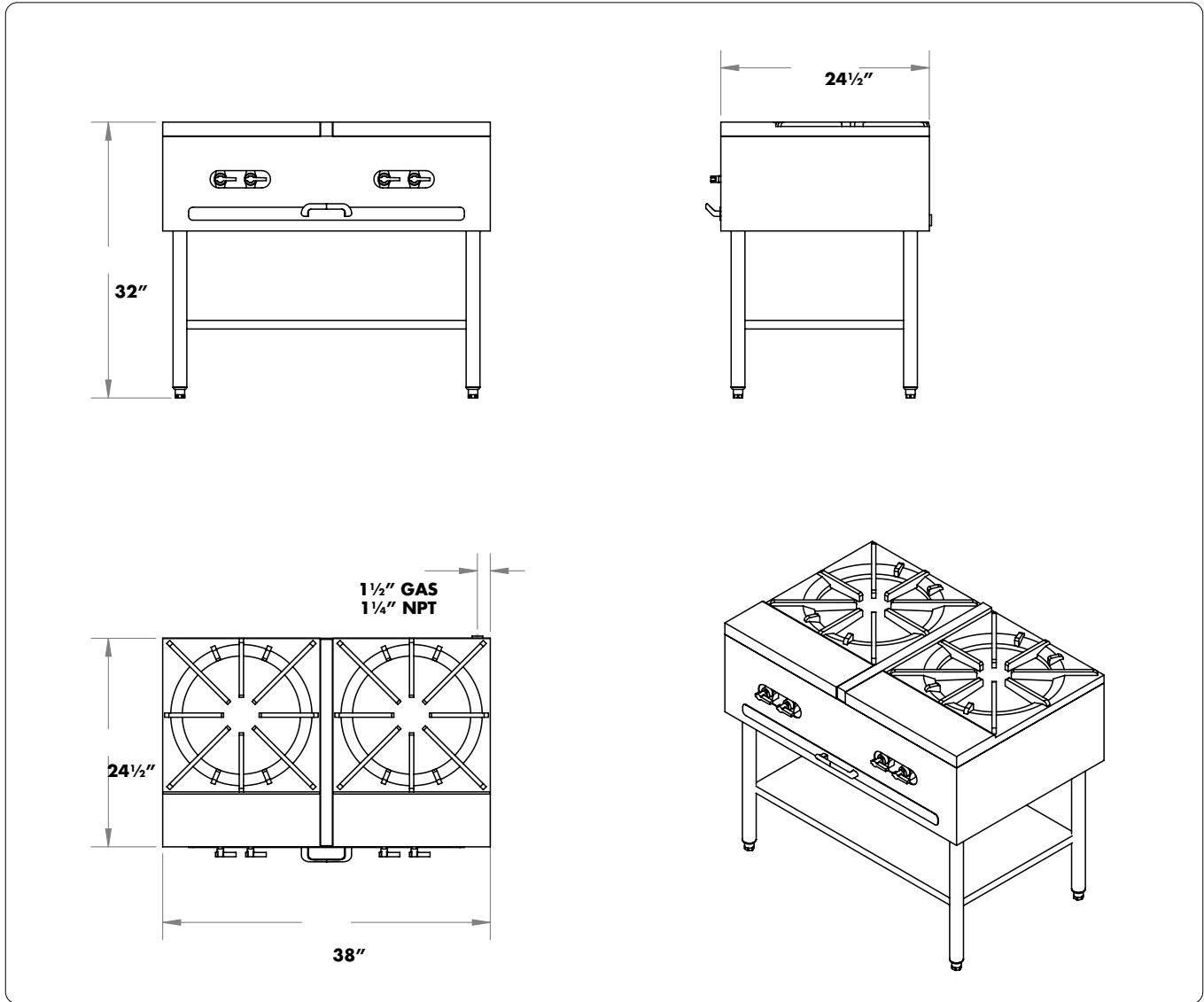

IMPORTANT

Commercial gas range(s) must be installed in accordance with state and local codes, or in the absence of local code with the NATIONAL FUEL GAS CODE- ANSI Z223.1. COMPLIANCE WITH ALL CODES IS THE RESPONSIBILITY OF THE OWNER AND THE INSTALLER.

COMMERCIAL GAS UNITS NEED ADEQUATE VENTILATION SYSTEMS. REFER TO *National Fire Protection Association Standard No. 96- "Vapor Removal from Cooking Equipment"*

MINIMUM CLEARANCES- COMBUSTIBLE AND NON-COMBUSTIBLE:

Back Wall- 6" Left and Right Sides- 6" For use on non-combustible floors only.

TOWN RESERVES THE RIGHT TO CHANGE DESIGN WITHOUT NOTIFICATION.



TOWN

FOOD SERVICE EQUIPMENT CO., INC.

Town Food Service Equipment Co., Inc. logo in Chinese characters: 敦富公司



800/221.5032
718/388.5650



718/388.5860



customerservice@townfood.com



townfood.com